

# Standard practice for installing cellulose building insulation



*Cellulose insulation can be installed in attics, walls, ceilings, floors, and other building assemblies using a variety of standard accepted techniques. This guide covers typical assembly designs and some of the more common installation methods that can be used to insulate new and existing residential structures.*



---

**applegateinsulation**

**800-627-7536**

**[www.applegateinsulation.com](http://www.applegateinsulation.com)**

## 1.0 SCOPE

This recommended practice covers the application of cellulosic loose fill thermal insulation in attics, sidewall cavities and between floors of single and multi family dwellings by means of pneumatic equipment and by pouring in place in attics.

## 2.0 SIGNIFICANCE

The purpose of this recommended practice is to inform installers, system designers and consumers of acceptable procedures to insure proper installation. It also identifies some of the precautions which need to be taken.

## 3.0 APPLICABLE DOCUMENTS

### 3.1 ASTM Standards

C-168-02 *Standard Terminology Relating to Thermal Insulating Materials*

C-739 *Standard Specification for Cellulosic Fiber (Wood Base) Loose Fill Thermal Insulation*

C-755-02 *Standard Practice for Selection of Vapor retarders for Thermal Insulation*

C-1149-02 *Standard Specification for Self-Supported Spray Applied Cellulosic Thermal/Acoustical Insulation*

C-1015 *Standard Practice for Installation of Cellulosic and Mineral Fiber Loose-Fill Thermal Insulation*

E-241 *Standard Guide for Limiting Water-Induced Damage to Buildings*

### 3.2 Federal Regulations

16 CFR Part 1209 *Consumer Products Safety Commission Interim Safety Standard for Cellulose Insulation*

16 CFR Part 460 *FTC Trade Regulation Rule, Labeling and Advertising of Home Insulation*

## 4.0 DEFINITIONS

**4.1** Backer board - a rigid, non vapor barrier forming material such as rock lath, treated cardboard, plywood, netting, etc. which is used to cover the open side of an existing wall and forms a cavity which may be filled with loose fill insulation. It must have sufficient strength to withstand the pressure developed when filling the cavity.

**4.2** Blocking - a material used to retain the insulation in place in open areas.

**4.3** Fill tube - a tube which enables a cavity to be filled through a single entry hole.

**4.4** Enclosed ceiling cavities - a ceiling area which is covered on both top and bottom.

## 5.0 PRELIMINARY INSPECTION

**5.1** An inspection of the building should be made prior to installation. Special consideration should be given to the following areas.

**5.1.1** Holes in ceilings or sidewalls, that would allow the insulation to escape, should be sealed.

**5.1.2** Weak areas of interior walls that may not be able to withstand pressures during the filling operation, should be reinforced or filled using less pressure.

**5.1.3** Walls with alterations, such as build-in bookshelves and cabinets, which may create isolated cavities, will require special entry holes.

**5.1.4** Wall cavities, which are used as air ducts for heating or air conditioning systems, must not be filled with insulation.

**5.1.5** Openings in heating or air conditioning air systems, in insulated areas, must have blocking placed around them.

**5.1.6** Wall cavities, which open into basements

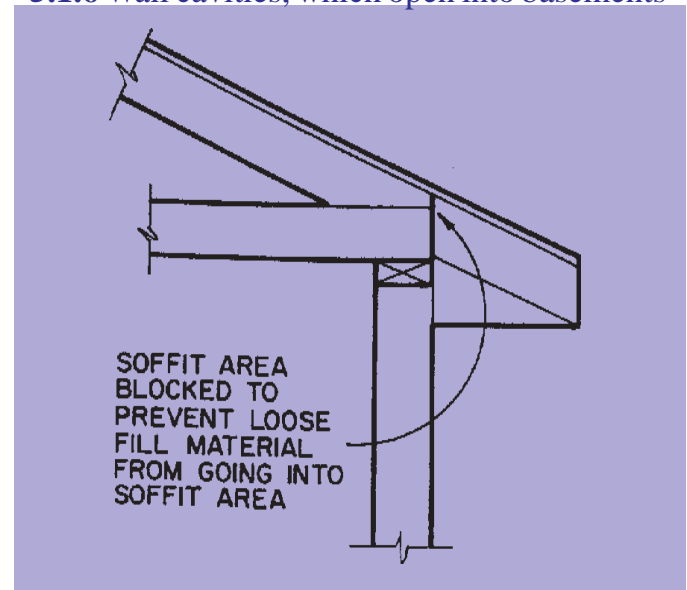

Figure 1A

or crawl spaces, must be sealed.

**5.1.7** The external siding of existing buildings should be inspected for paint peeling or other evidence of moisture problems. Insulation alone may not solve such problems. Other remedial actions may be necessary. (See Sections 9 and 10 for steps to be followed.)

## 6.0 PREPARATION

### 6.1 New Construction

**6.1.1** Where individual vents are used in the soffit, the rafter space immediately in front of and on either side of the vent should be provided with an air chute (see Fig. 1A and Fig. 1B). Other spaces should be totally blocked.

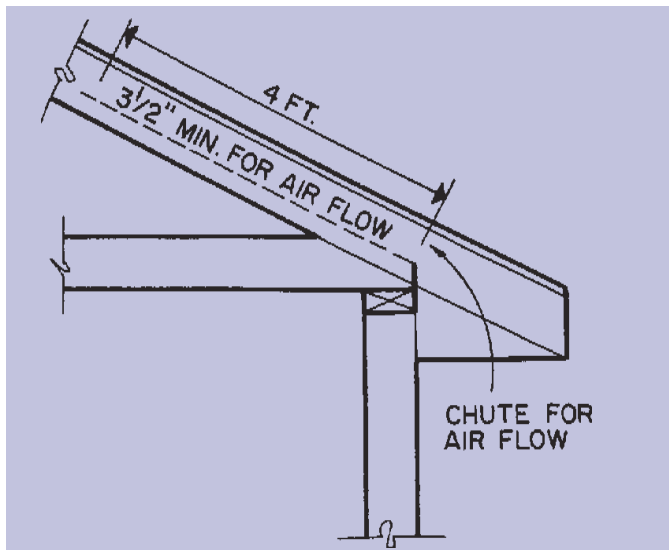

**Figure 1B**

**6.1.2** Where a continuous strip vent is used in the soffit, an air chute should be provided in every rafter space (see Fig. 1A and 1B).

**6.1.3** All voids around windows and doors should be sealed to stop air infiltration. Various materials such as foam backer rod or urethane spray foam are available for this purpose. See Note 1. Note 1 - Avoid use of expanding foams around windows. Some windows (vinyl, aluminum framed) can warp, preventing them from operating. Additionally, some window manufacturers will not honor warranties if foam is used, even if the foam is non-expanding.

**6.1.4** Insulating the corners of attics in buildings with hip roofs may require special nozzles or placement tools. Alternately, corners can be insulated with suitable insulation before the dry-wall or plasterboard is installed. Any other areas inaccessible after the interior finish is installed must be handled in like manner.

## **6.2 Existing Structures**

In joist areas, where soffit vents are installed, the opening from the attic into the soffit area may be treated as described in 6.1.1 and 6.1.2. Install chute as per Section 6.0 and Figure 1B.

## **6.3 New and Existing structures**

**6.3.1** Blocking should be placed around access to the attic to prevent insulation from falling out.

**6.3.2** Blocking should be placed around recessed light or heating fixtures, chimneys and flues. Clearance between heat producing elements and combustible constructions should follow applicable codes. Blocking should be permanently placed so as to keep insulation a minimum of three inches away from all sides of

recessed lighting fixtures and other heat-producing devices. The open area above recessed lighting fixtures and other heat-producing devices should not be insulated per the National Electrical Code. The exception to this is IC rated light fixtures.

**6.3.3** Cabinet bulkheads, stairway wells and wall cavities which open into the attic should be covered by a retainer to support the insulation. (See 4.1)

**6.3.4** The open side of any wall between a heated and unheated area should be covered by a retainer to form a cavity to retain loose fill material.

## **7.0 COVERAGE REQUIREMENTS**

When installing insulation, care should be taken not to exceed the square foot coverage shown on the label. The labeled thickness is the minimum thickness required for a given R-value. The initial installed thickness in ceiling applications may exceed that shown on Applegate Insulation's label because of potential settling. The bag count and weight-per-square-foot requirements of the coverage chart must be followed to provide the specified R-value at settled density.

## **8.0 APPLICATION PROCEDURES**

### **8.1 Ceiling Areas**

#### **8.1.1 Accessible Ceilings**

**8.1.1** When installing insulation by pneumatic means, it is important that the application machine be set as recommended by the machine manufacturer.

#### **8.1.2 Enclosed Ceiling Cavities**

Installations of this type must be made by pneumatic means and the cavity should be completely filled. This is done by inserting a fill tube into each cavity and withdrawing it as the cavity is filled. The air setting on the machine should be set as recommended by the machine manufacturer for sidewall application.

### **8.2 Sidewalls (Existing Buildings)**

Installation into sidewall cavities must be made by pneumatic means. The air setting on the machine should be set as recommended by the machine manufacturer according to the size nozzle being used. After fill holes are drilled, all cavities should be checked for fire blocks or other obstructions with an electrician's fish tape or other similar tool. A mathematical check should be made in the first few stud space to assure that the proper amount of insulation is being installed

**8.2.1** Filling through external siding in applications of this type, the following procedure is

recommended. Drill holes 5/8 inch to 2 inches (1.59 to 5.08 cm) in diameter, depending on the siding, in each wall cavity. Vertical distance between a hole and top or bottom plate should not exceed 2 feet (.62 m) and the vertical distance between holes should not exceed 5 feet (1.52 m). Homes with shingle or lapped siding should have the holes drilled as near the shadow line as possible. Homes with brick veneer should have holes 5/8 inch to 3/4 inch (1.59 to 1.9 cm) in diameter drilled in the mortar joints. All holes should be filled with suitable plugs. (See Figure 4).

**8.2.2** Filling with fill tube in some applications is desirable. When using this method, only one entry hole per cavity is necessary. The fill tube should be inserted far enough to reach within 18 inches (45.72 cm) of the plate farthest from the

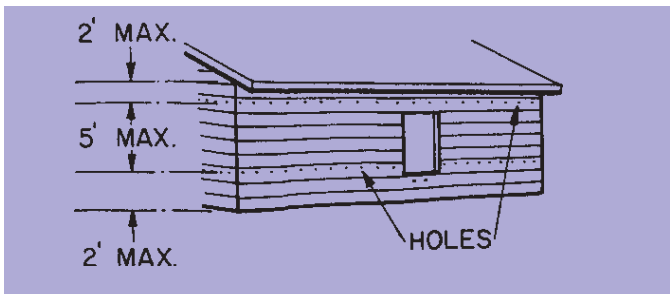

**Figure 4**

point of entry. Fill tube size will depend upon the size of hole which can be drilled. (See Figure 5 for alternate points of entry for the fill tube.

### 8.3 Sidewalls (New Construction)

The same installation techniques used with existing walls are occasionally employed in new construction, however insulation is usually installed in new walls before the walls are closed using wall-spray or dry application techniques.

**8.3.1** Cellulose insulation for wall-spray application in new walls is classified as Type II Material under ASTM Standard C-1149. These materials may contain adhesive to produce cohesion necessary to make the insulation self-supporting. The adhesive may be liquid added during the installation process, or it may be dry adhesive contained in the insulation and activated by moisture during application.

The insulation is sprayed into the wall cavities from inside the building. Many application systems are proprietary and are designed for use with specific products. Applegate Insulation's instructions with regard to application equipment and its use should be followed explicitly, as should Applegate's instructions on the amount to

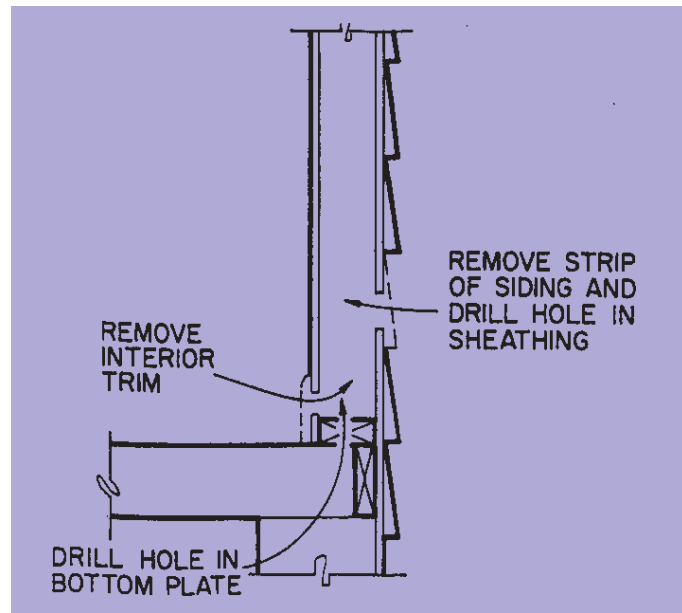

**Figure 5**

be added during application. All pipes, ducts, conduits, wiring, and outlets should be installed in the wall before the insulation is applied. Windows and areas from which insulation is to be excluded, such as electrical boxes, should be masked.

After application the insulation is made even with the stud faces by a "stud scrubber." The wall can be closed shortly after installation of the insulation. Ideally, interior finish can be installed when moisture content is 25%. Most authorities agree that vapor retarders of any type should not be used with spray-applied cellulose. This recommendation may conflict with some building codes, but knowledgeable code officials understand the special nature of wall-spray cellulose and normally grant exceptions when the material is used.

**8.3.2** Various types of permanent retainer systems are used to install dry cellulose insulation in new walls. All systems are proprietary, and the manufacturers provide detailed instructions, and often special training programs, for their use. All systems require pneumatic installation and compression of the material to sufficient density to prevent settlement. Semi-spiral hose shall be used. This hose allows the material to tumble and stay in the air stream.

**8.3.3** Dry cellulose insulation can be installed in new walls using temporary retainers that are clamped in place to create a closed cavity. Insulation is blown into the temporary cavity at sufficient density to keep it in place when the retainer is removed. An installed density of 3.5 to

4.0 p.c.f. may be necessary.

## 9.0 VAPOR RETARDERS

**9.1** A ground surface vapor retarder such as plastic film is recommended when there is a crawl space beneath the floor. (See Section 10.0 for Ventilation)

## 10.0 VENTILATION

### 10.1 Attic Ventilation

**10.1.1** In vented attics without vapor retarders standard practice is to provide one square foot (.093 m<sup>2</sup>) of net vent area for each 150 square feet (13.94 m<sup>2</sup>) of ceiling area.

**10.1.2** In vented attics with vapor retarders standard practice is to provide one square foot (.0903 m<sup>2</sup>) of net vent area for each 300 square feet (27.87 m<sup>2</sup>) of attic floor area.

**10.1.3** When using a combination of roof and eave vents, and no ceiling vapor barrier, there should be 1 square foot (.093 m<sup>2</sup>) of net vent area for each 300 square feet (27.87 m<sup>2</sup>) of ceiling area. Vents should be installed with 50% of the total area in the eaves and 50% of the total area in the roof near the peak.

### 10.2 Unconditioned Crawl Space Ventilation

There should be 1 square foot (.093 m<sup>2</sup>) of net vent area for each 150 square feet (13.94 m<sup>2</sup>) of floor area.

### 10.3 "Conditioned" Crawl Spaces

No ventilation is required. Instead, line crawlspace floors with a plastic vapor barrier extending up the crawlspace wall 4-6" sealing all seams; insulate crawlspace walls; and introduce conditioned air into crawlspace.

## 11.0 PRECAUTIONS AND LIMITATIONS

**11.1** Heaters and recessed light fixtures must not be covered by the insulation, unless the fixture has an IC rating. Local and national codes must be followed if applicable. A minimum of 3 inches (7.62 cm) of air space must be maintained between fixtures and the blocking.

**11.2** Cold air returns and combustion air intakes for hot air furnaces must not be blocked or insulation be installed in a manner which would allow it to be drawn into the system.

**11.3** Insulation must not contact chimneys or flues in excess of 180 degrees. A minimum of 3 inches (7.62 cm) of air space must be maintained with blocking used to retain the insulation.

**11.4** The homeowner should be advised that in tightly constructed homes or when insulating existing homes which have fuel fired heating systems

within the living area or basement, an air duct must be installed between the furnace room and a well ventilated outside area to provide combustion air. A local heating contractor should be contacted for proper duct size and installation.

**11.5** The homeowner should be advised that the relative humidity within the living area should be kept below 40% R.H. when outside temperatures fall below 32 degrees F. (0 degrees C.)

**11.6** This insulation is not recommended for use in sidewalls below grade.

**11.7** This insulation is not recommended for filling the cavities of masonry walls.

**11.8** This insulation is to be used in the temperatures range of -50 degrees F. to 180 degrees F. (-45.6 degrees C to 82.2 degrees C.)

**11.9** The installer must wear appropriate respiratory protective equipment.

**11.10** Installers and specifiers are advised to refer to other relevant documents, including the National Electrical Code, ASTM Standard Designation C1015, etc., for additional information.

Additional information of interest to installers and specifiers is contained in the publication *Cellulose insulation: codes, regulations, and specifications*, which is available from Applegate Insulation.

---

## The *natural* superiority of cellulose

Higher R-per-inch values than most comparable fiber insulation materials.

Tightens buildings against air infiltration better than fiber glass insulation. A study by the University of Colorado School of Architecture and Planning found cellulose at least 36 percent better than fiber glass in tightening buildings.

Not subject to extreme convective heat loss, which has been shown to reduce the actual R-value of loose-fill fiber glass insulation by up to 50 percent under winter conditions. Oak Ridge National Laboratory measured R-values as low as R-12 at an attic temperature of 9 degrees F for an "R-19" fiber glass installation.

Less subject to installation defects that can seriously erode the installed performance of batt systems.

Increases fire resistance of walls up to 55%; fiber glass slightly decreases fire resistance.

"R" for "R" requires much less energy to produce than mineral fiber insulation, which is made in gas-fired furnaces. According to authoritative estimates it takes from 20 to 200 times more energy to make fiber glass than to produce an equivalent amount of cellulose.

Productively recycles the largest single component of the residential waste stream.

Overall, insulates homes better. Colorado University researchers reported that cellulose performs 26 percent better than fiber glass in temperature climates and as much as 38 percent better in cold climates.



**applegateinsulation**

1000 Highview Drive  
Webberville, MI 48892  
(800) 627-7536

Serve the LORD with fear, and rejoice with trembling. (Psalm 2:11)  
Copyright 2008 Applegate Holdings, LLC

---